





**PRODUCT INDEX**

<i>Aluminium slatwall panel system and accessories</i>	Q-16 to 19
<i>Axe display for aluminium slatwall or pegboard</i>	Q-20
<i>Baseboard heater display</i>	Q-04
<i>Bin shelf, bin shelf divider and sub-divider</i>	Q-04
<i>Bulk merchandise bin shelf &amp; divider</i>	Q-05
<i>Caulking tube shelf &amp; divider</i>	Q-05
<i>Ceiling light and fan display</i>	Q-12
<i>Crossbar 1 x 2 x 48" and accessories</i>	Q-08, 09
<i>Cutter for meter</i>	Q-03
<i>Door display</i>	Q-11
<i>Dowel display</i>	Q-09
<i>Electrical breaker display with acrylic door</i>	Q-01
<i>Fan belt display</i>	Q-12
<i>Horizontal pipe display or long material</i>	Q-10
<i>Ladder and step-ladder display</i>	Q-10
<i>Lighting display bracket</i>	Q-07
<i>Lighting display panel system for Boni-type gondola</i>	Q-13
<i>Lock</i>	Q-01
<i>Long material display</i>	Q-09
<i>Metal showcase with glass doors</i>	Q-01, Q-14
<i>Meter</i>	Q-03
<i>Meter &amp; winder crossbar</i>	Q-03, 04
<i>Pegboard page display</i>	Q-11
<i>Plastic box crossbar</i>	Q-06
<i>Pre-cut panel display</i>	Q-13
<i>Pre-finish panel display page</i>	Q-11
<i>Range hood fan display arm</i>	Q-05
<i>Sample page display</i>	Q-10
<i>Sandpaper display</i>	Q-05
<i>Saw blade display</i>	Q-07
<i>Sink display arm</i>	Q-05
<i>Sink or range hood display crossbar</i>	Q-05
<i>Sledgehammer display for aluminium slatwall or pegboard</i>	Q-20
<i>Sliding perforated panel</i>	Q-01
<i>Spool display</i>	Q-02, 03
<i>Toilet seat bracket</i>	Q-06
<i>Toilet seat display</i>	Q-06
<i>Vinyl floor tile display</i>	Q-10
<i>Vinyl roll display</i>	Q-06
<i>Winder</i>	Q-03
<i>Wiremesh door</i>	Q-14

**SLIDING PERFORATED PANEL**

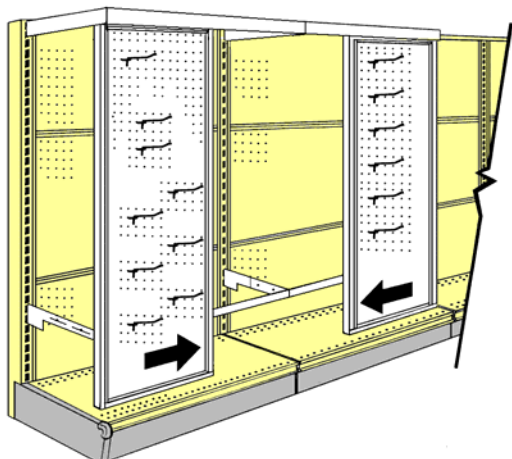

Available in section of 48" wide with one 24" wide panel sliding on a 48" long track.

The height and depth will be adapted to your specifications.

**METAL SHOWCASE WITH GLASS DOORS**

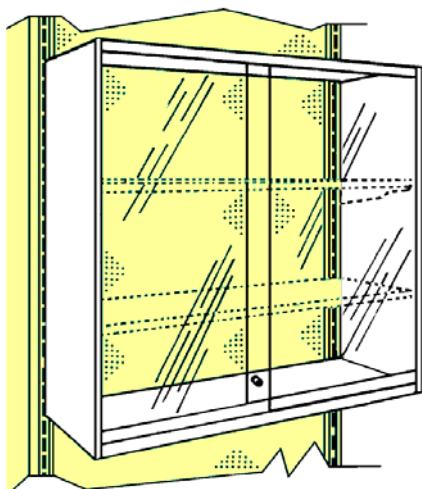

- With metal top**  
 022-03-4830 12" deep x 30" high x 48" wide  
 022-03-4847 16" deep x 47" high x 48" wide  
 022-04-4830 16" deep x 30" high x 48" wide

- With glass top**  
 ARM-00-4816 16" deep x 42" high x 48" wide

**(shelves & lock not included)**

As an option, it is possible to have the side panels perforated for the storage of pesticides. (see page Q-14)

**LOCK**

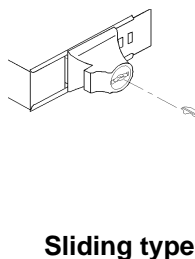
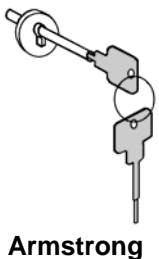

- 022-03-0000 Sliding type lock for metal showcase with glass doors TDK7  
 022-03-0005 Armstrong type lock for metal showcase with glass doors

**ELECTRICAL BREAKER DISPLAY WITH ACRYLIC DOOR**

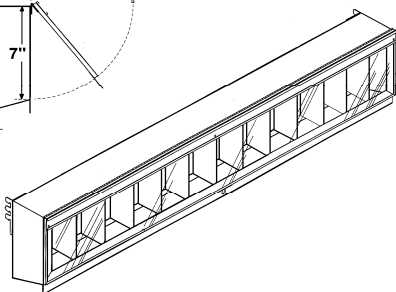
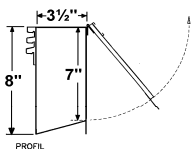

- 030-37-0848 8" high x 48" long  
 (13 spaces of 3 5/8" wide)

**SINGLE SPOOL DISPLAY**

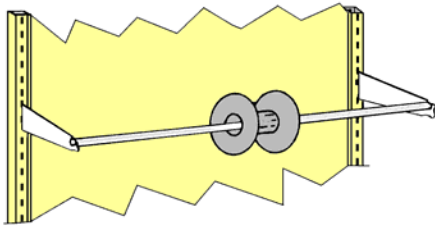

- PRF-01-3008 8" x 30"
- PRF-01-3608 8" x 36"
- PRF-01-4808 8" x 48"
  
- PRF-01-3012 12" x 30"
- PRF-01-3612 12" x 36"
- PRF-01-4812 12" x 48"

**DOUBLE SPOOL DISPLAY**

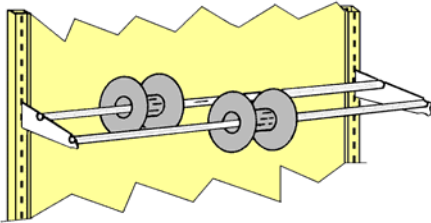

- PRF-02-3012 12" x 30"
- PRF-02-3612 12" x 36"
  
- PRF-02-4812 12" x 48"
- PRF-02-4816 16" x 48"

**SPOOL DISPLAY BRACKET**

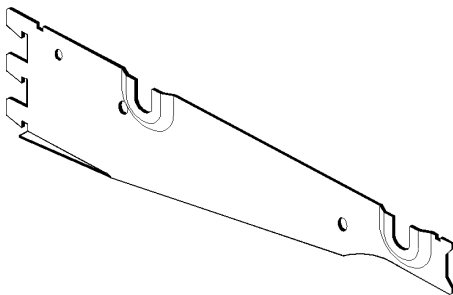

**Left**

- 006-10-G0008 8"
- 006-10-G0012 12"
- 006-10-G0016 16"

**Right**

- 006-10-D0008 8"
- 006-10-D0012 12"
- 006-10-D0016 16"

**SPOOL DISPLAY ROD - CHROME**

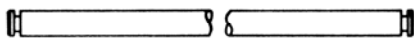

- 016-22-0030 30"
- 016-22-0036 36"
- 016-22-0048 48"
- 016-22-0056 56"

**SPOOL DISPLAY**

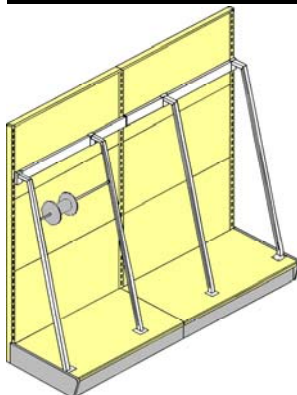

- 030-18-0004 73" high centre leg
- 030-18-0003 73" high end leg
  
- 030-04-0048 48" crossbar
  
- 030-18-0001 Tube bracket
- 030-18-0002 5/8" x 29½" tube

*(gondola not included)*

**HEAVY SPOOL DISPLAY**

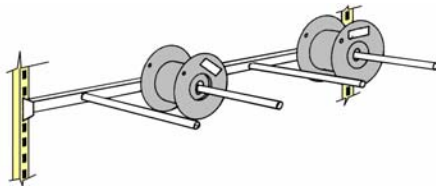

016-21-0003 3 tubes

016-21-0004 4 tubes

**SPOOL DISPLAY**

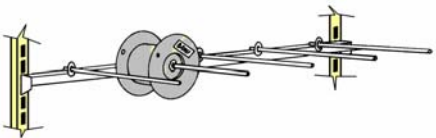

016-21-0003A 3 rods (5/8" dia.)

016-21-0004A 4 rods (5/8" dia.)

016-21-0005A 5 rods (5/8" dia.)

**METER**

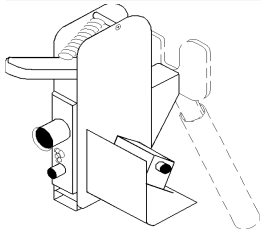

016-21-0000 Metric model 1420

016-21-0000A Imperial model 1410  
(special order)

016-21-0000A Imperial model 1430 (for rope)  
(special order)

**CUTTER FOR METER**

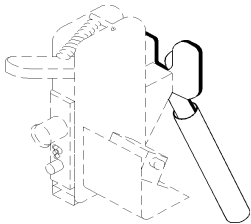

016-21-0100

**WINDER**

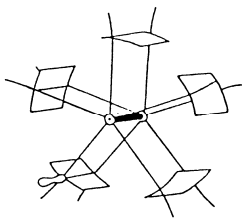

016-21-0001 Model 99

**METER AND WINDER CROSSBAR**

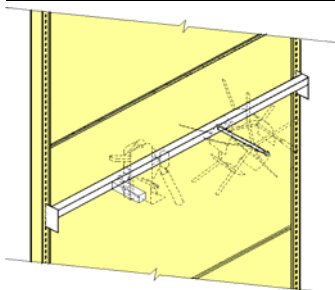

016-21-0002 48"

**SLIDING BASE KIT FOR METER**

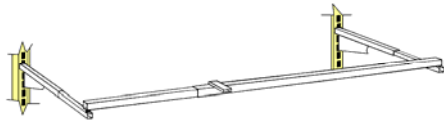

- 016-21-0048 20" x 48"
- 016-21-0096 20" x 96"

**BASEBOARD HEATER DISPLAY**

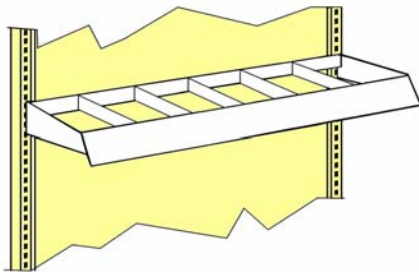

- 030-26-4816 16" x 48" with 5 dividers
- 030-26-4820 20" x 48" with 5 dividers
- 030-27-4816 16" x 48" without divider

**BIN SHELF**

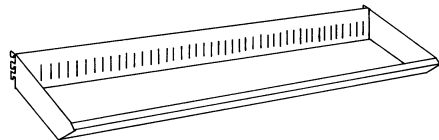

- 023-01-3608 8" x 36"
- 023-01-3610 10" x 36"
- 023-01-3612 12" x 36"
- 023-01-3614 14" x 36"
- 023-01-3616 16" x 36"
- 023-01-4808 8" x 48"
- 023-01-4810 10" x 48"
- 023-01-4812 12" x 48"
- 023-01-4814 14" x 48"
- 023-01-4816 16" x 48"

**BIN SHELF DIVIDER**

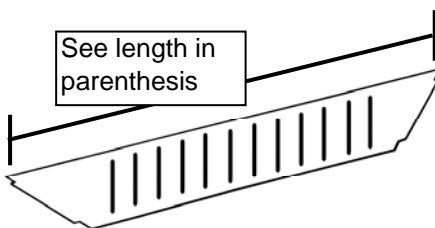

See length in parenthesis

- 023-01-0008 8" (6 7/8") no slot for sub-divider
- 023-01-0010 10" (8 7/8")
- 023-01-0012 12" (10 7/8")
- 023-01-0014 14" (12 7/8")
- 023-01-0016 16" (14 7/8")

**BIN SHELF SUB-DIVIDER**



- 023-01-0004 4"
- 023-01-0006 6"

**BULK MERCHANDISE BIN SHELF**

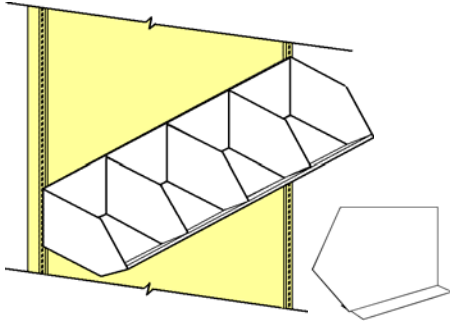

- 023-02-0036 9" x 16" x 36"
- 023-02-0048 9" x 16" x 48"
- 023-02-0000 *Divider for bulk merchandise bin shelf*

**CAULKING TUBE SHELF**

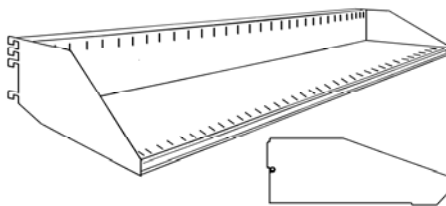

- 031-09-0030 14" (12") x 30"
  - 031-09-0036 14" (12") x 36"
  - 031-09-0048 14" (12") x 48"
  - 031-09-0001 *Divider for caulking tube shelf 14" (12") deep.*
- Can also be used as a catalogue or bag storage shelf.*

**SANDPAPER DISPLAY**

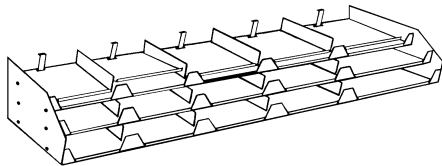

- 030-11-0030 30" (9 spaces)
- 030-11-0048 48" (15 spaces)

**SINK OR RANGE HOOD FAN DISPLAY**

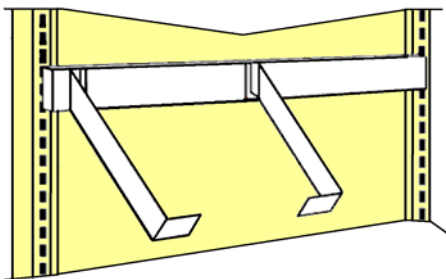

**CROSSBAR**

- 030-04-0036 4" x 36"
- 030-04-0048 4" x 48"

**SINK BRACKET**

- 006-13-0020 20" right side bracket for sink display
- 006-13-0021 20" left side bracket for sink display

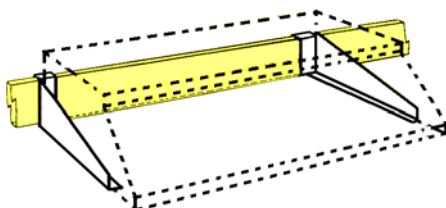

**RANGE HOOD FAN DISPLAY BRACKET**

- 023-25-0001 *Right*
- 023-25-0011 *Left*

*Crossbar sold separately*

**TOILET SEAT BRACKET**

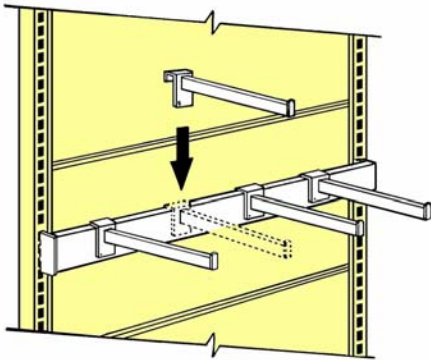

030-30-0012 1/2" x 1 1/2" x 12"

030-30-0016 1/2" x 1 1/2" x 16"

Crossbar sold separately Q-05

**CROSSBAR**

030-04-0036 4" x 36"

030-04-0048 4" x 48"

**TOILET SEAT DISPLAY**

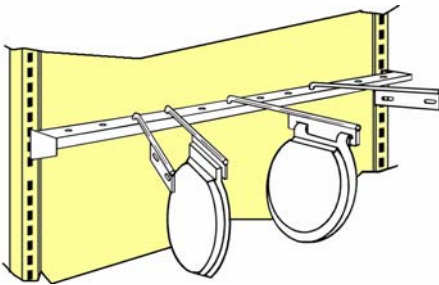

030-30-0036 36" - 12 arms

030-30-0048 48" - 16 arms

**VINYL ROLL DISPLAY**

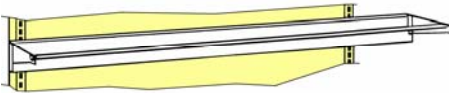

031-06-0056 56" long (rod included below)

**ROD FOR VINYL ROLL DISPLAY**

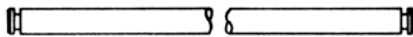

016-22-0056 56"

**PLASTIC BOX CROSSBAR**

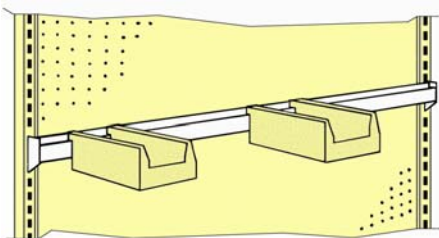

030-28-0030 24"

030-28-0036 36"

030-28-0048 48"

(Plastic box not included, supply a sample of your plastic boxes)

**VERTICAL CIRCULAR SAW BLADE DISPLAY**

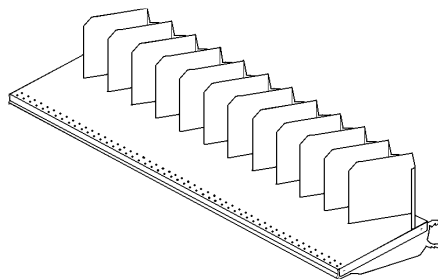

030-10-0036 12" x 36" - 12 spaces

030-10-0048 12" x 48" - 17 spaces

*(brackets included)*

**CIRCULAR SAW BLADE DISPLAY 3, 4 OR 5-TIER**

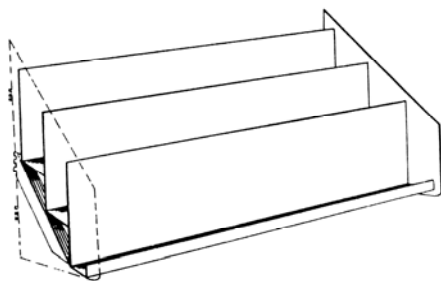

018-03-0036 36" - 3-tiers

018-04-0036 36" - 4-tiers

018-05-0036 36" - 5-tiers

018-03-0048 48" - 3-tiers

018-04-0048 48" - 4-tiers

018-05-0048 48" - 5-tiers

**END FOR SAW BLADE DISPLAY**

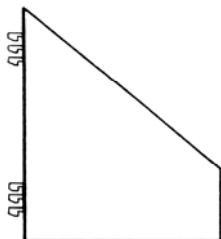

019-G3-0002 *Left 3-tiers*

019-G4-0002 *Left 4-tiers*

019-G5-0002 *Left 5-tiers*

019-D3-0002 *Right 3-tiers*

019-D4-0002 *Right 4-tiers*

019-D5-0002 *Right 5-tiers*

**BRACKET FOR LIGHTING DISPLAY**

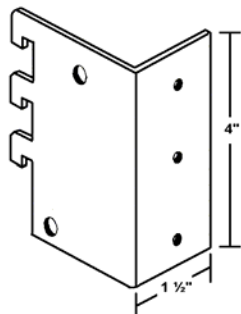

*4" high x 1 1/2" wide x 2" deep*

039-G2-0001 *Left*

039-D2-0001 *Right*

**1" X 2" X 48" CROSSBAR**

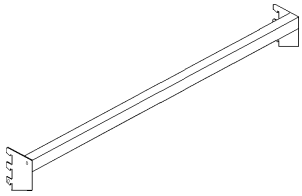

030-04-0148 48"

**ACCESSORIES FOR 1" X 2" X 48" CROSSBAR**

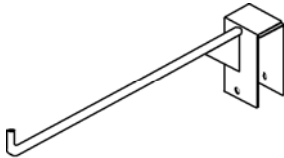

**SINGLE PRONG DISPLAY**

006-22-0010 10"  
006-22-0014 14"

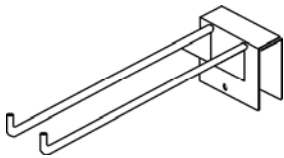

**DOUBLE PRONG DISPLAY**

006-23-0010 10"  
006-23-0014 14"

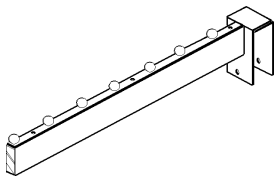

**AXE OR SHOVEL DISPLAY**

006-24-0014 14"

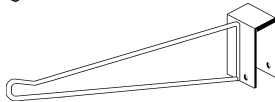

**RAKE DISPLAY**

006-26-0014 14"  
*Can also be used as a moulding divider*

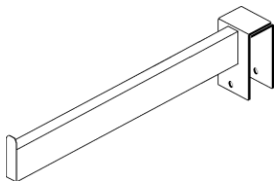

**TOOL DISPLAY**

006-27-0010 10"  
006-27-0014 14"

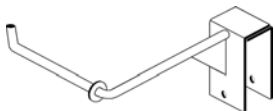

**BOW SAW DISPLAY**

006-28-0001 10"

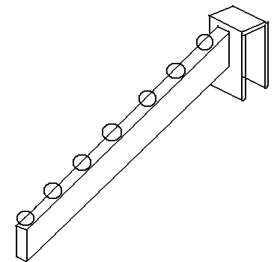

**T-SQUARE DISPLAY**

006-29-0014 14"



**DISPLAY HOOK**

016-41-0006 6"  
016-41-0008 8"  
016-41-0012 12"

**CROSSBAR AND DIVIDER FOR COUNTER TOP**

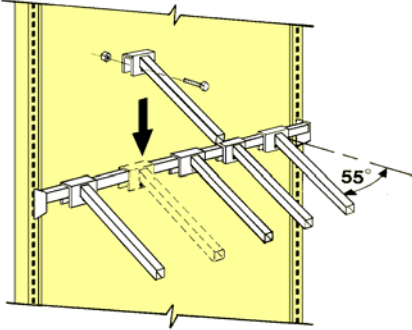

**COUNTER TOP DIVIDER**

030-19-0029 1" x 1" x 29"

**CROSSBAR FOR DIVIDER**

030-19-0048 1¼" x 1¼" x 48"

030-19-0096 1¼" x 1¼" x 96"

**LONG MATERIAL DISPLAY**

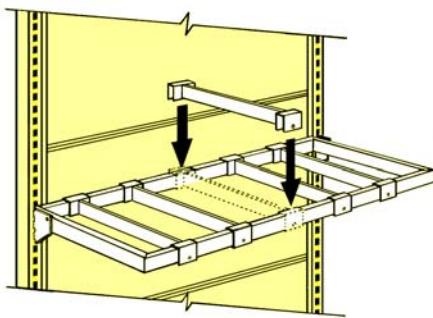

**FRAME**

030-09-4816 16" x 48"

030-09-4818 18" x 48"

030-09-4820 20" x 48"

**DIVIDER**

030-09-0016 16"

030-09-0018 18"

030-09-0020 20"

**LONG MATERIAL DISPLAY**

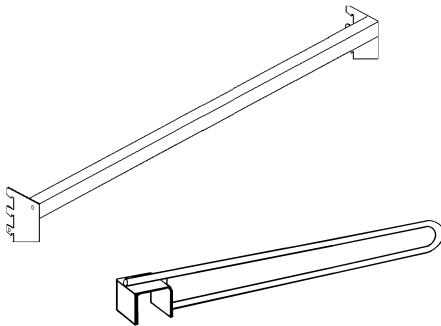

**CROSSBAR**

030-07-0036 1" x 1" x 36"

030-07-0048 1" x 1" x 48"

**DIVIDER**

016-25-0016 16"

**DOWEL DISPLAY**

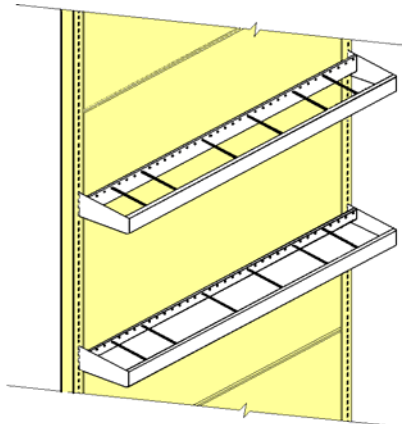

**FRAME**

PRG-00-0030 30" with 14 dividers

PRG-00-0036 36" with 16 dividers

PRG-00-0048 48" with 20 dividers

**FRAME**

023-04-0001

**HORIZONTAL DISPLAY FOR PIPE OR LONG MATERIAL**

**EXTENSION KIT ONLY**

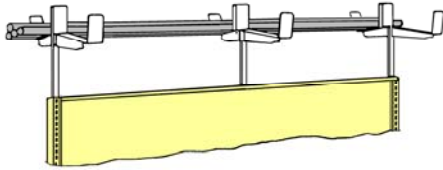

031-08-0012 For a 12' section 12' (3 x 4')

**BRACKET FOR PIPE OR LONG MATERIAL**



006-09-0012 12"

006-09-0014 14"

006-09-0016 16"

006-09-0018 18"

**LADDER AND STEP-LADDER DISPLAY**

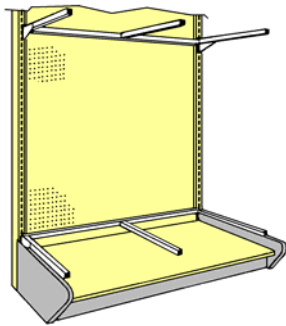

031-07-0036 20" x 36" (2 parts)

031-07-0048 20" x 48" (2 parts)

(gondola not included)

**SAMPLE DISPLAY PAGES**

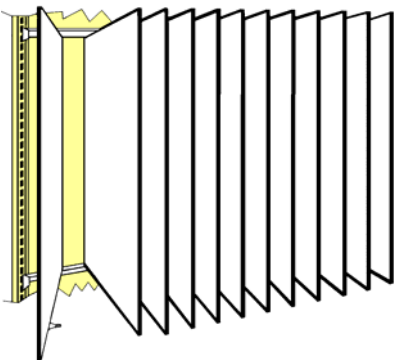

031-04-0048 22" x 48" with 12 pages

031-04-0001 Additional page 22" x 48"

**VINYL FLOOR TILE DISPLAY**

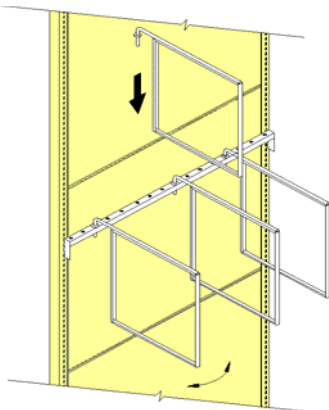

**CROSSBAR**

033-06-0048 48" with 16 holes

**PAGE**

033-06-1212 12" x 12"

**PEGBOARD DISPLAY PAGE**

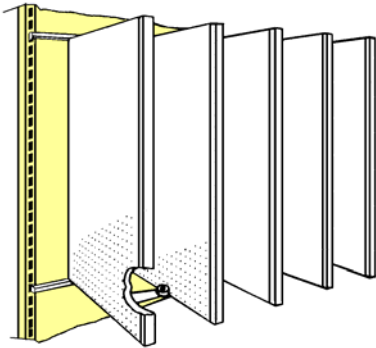

031-05-0048 48" long, with 5 pages 22" x 47"

031-15-2247 Additional page 22" x 47"

**SINGLE HOOK FOR MASSONITE BACKING**



016-30-0002 2" (box of 100)

**DOOR DISPLAY**

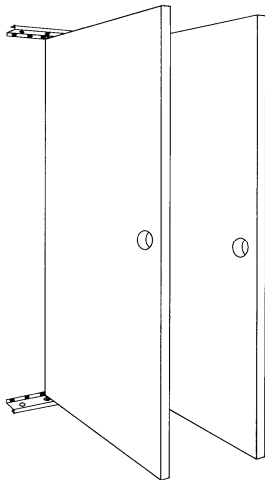

**FOR BONI STRUCTURE (96" HIGH)**

031-03-0036 36" with attachments for 12 doors

031-03-0048 48" with attachments for 16 doors

**TO BE ANCHORED TO A WALL**

031-03-0136 36" with attachments for 12 doors

031-03-0148 48" with attachments for 16 doors

**PRE-FINISH PANEL DISPLAY**

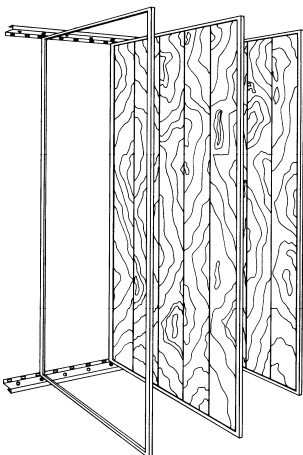

031-02-0036 36" - with 12 pages

031-02-0048 48" - with 16 pages

031-02-0000 Additional 48" x 96" page

(Wall attachment included)

**FAN BELT DISPLAY**

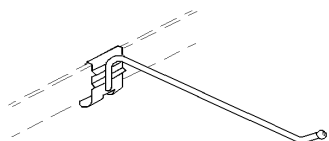
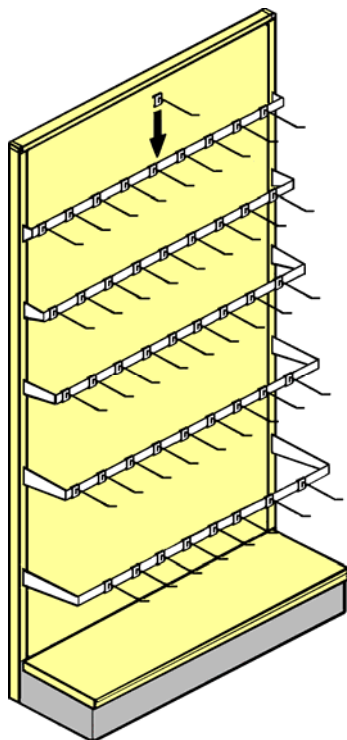

**CROSSBAR WITH BRACKETS**

Gondola and hooks are not included

- PRC-00-3001 1" x 30"
- PRC-00-3601 1" x 36"
- PRC-00-4801 1" x 48"
  
- PRC-00-3004 4" x 30"
- PRC-00-3604 4" x 36"
- PRC-00-4804 4" x 48"
  
- PRC-00-3008 8" x 30"
- PRC-00-3608 8" x 36"
- PRC-00-4808 8" x 48"
  
- PRC-00-3012 12" x 30"
- PRC-00-3612 12" x 36"
- PRC-00-4812 12" x 48"
  
- PRC-00-3016 16" x 30"
- PRC-00-3616 16" x 36"
- PRC-00-4816 16" x 48"

**4" HOOK**

016-40-0004

**CEILING LIGHT AND FAN DISPLAY**

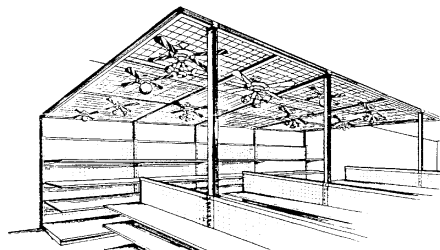

**DROPPED ON THE GONDOLA'S UPRIGHTS**

*MAXIMUM CAPACITY 50LB PER SQUARE FOOT*

*IT IS ALWAYS FORBIDDEN TO WALK ON THE TOP OF THE DISPLAY*

Pricing according to your specifications



**SUSPENDED TO THE CEILING**

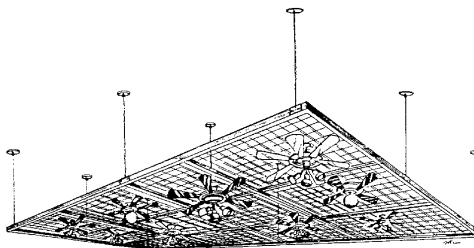

Pricing according to your specifications

**DISPLAY PANEL SYSTEM FOR LIGHTING DEPARTMENT  
FOR REGULAR BONI STRUCTURE**

*Each kit consists of a frame, 14" x 14" panels (assorted, some with 3 grooves, others plain and others with an octagonal hole) and filler panels. Panels are melamine finish.*

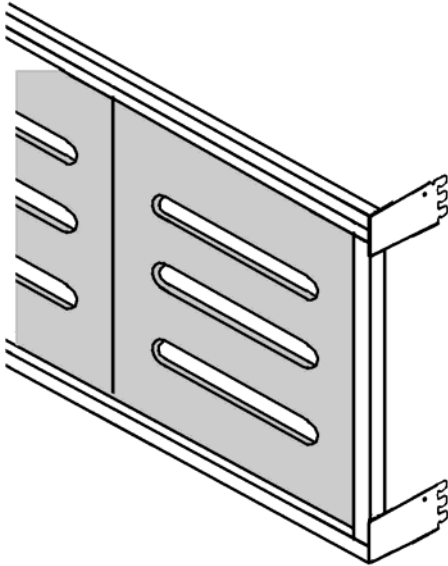

**SINGLE - 1 PANEL HIGH**

PRL-01-3630 36" wide x 16" high (2 panel wide)  
PRL-01-4830 48" wide x 16" high (3 panel wide)

**DOUBLE - 2 PANEL HIGH**

PRL-02-3630 36" wide x 30" high (2 panel wide)  
PRL-02-4830 48" wide x 30" high (3 panel wide)

**TRIPLE - 3 PANEL HIGH**

PRL-03-3648 36" wide x 48" high (2 panel wide)  
PRL-03-4848 48" wide x 48" high (3 panel wide)

**QUADRUPLE - 4 PANEL HIGH**

PRL-04-3648 36" wide x 63" high (2 panel wide)  
PRL-04-4848 48" wide x 63" high (3 panel wide)

**ACCESSORIES**

*14" x 14" x 5/8" panel with 3 grooves*

*14" x 14" x 5/8" panel with an octagonal hole*

*14" x 14" x 5/8" plain panel (edges all finished)*

**PRE-CUT PANEL DISPLAY**

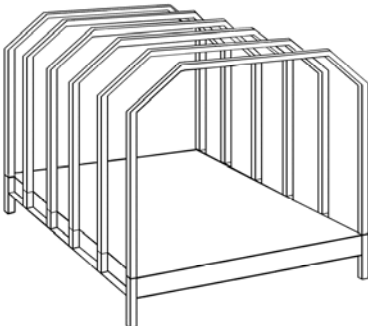

031-12-4848 with 6 dividers

**WIRE MESH DOORS FOR BONI STRUCTURE**

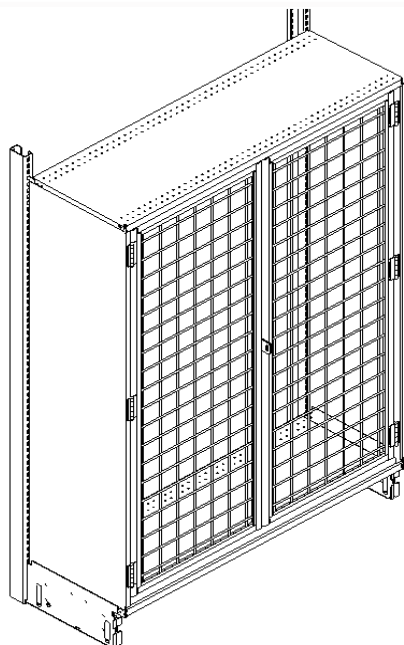

**FRAME WITH DOORS**

- 030-30-3048 48" wide x 30" high
- 030-30-3648 48" wide x 36" high
- 030-30-5248 48" wide x 52" high
- 030-30-6248 48" wide x 62" high
- 030-30-7648 48" wide x 76" high

**LEFT SIDE PANEL**

- 16" x 30" (for shelf with label moulding)
- 16" x 36" (for shelf with label moulding)
- 16" x 52" (for shelf with label moulding)
- 16" x 62" (for shelf with label moulding)
- 16" x 76" (for shelf with label moulding)

- 16½" x 30"
- 16½" x 36"
- 16½" x 52"
- 16½" x 62"
- 16½" x 76"

**RIGHT SIDE PANEL**

- 16" x 30" (for shelf with label moulding)
- 16" x 36" (for shelf with label moulding)
- 16" x 52" (for shelf with label moulding)
- 16" x 62" (for shelf with label moulding)
- 16" x 76" (for shelf with label moulding)

- 16½" x 30"
- 16½" x 36"
- 16½" x 52"
- 16½" x 62"
- 16½" x 76"

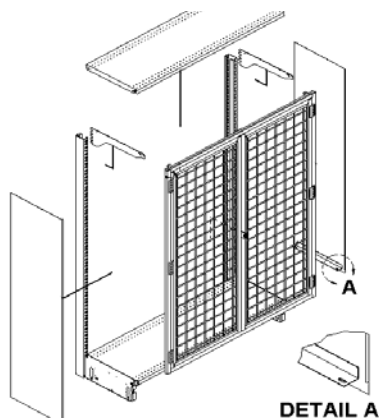

**Shelf, brackets and gondola not included**

**METAL SHOWCASE WITH GLASS DOORS AND PERFORATED SIDE PANELS**

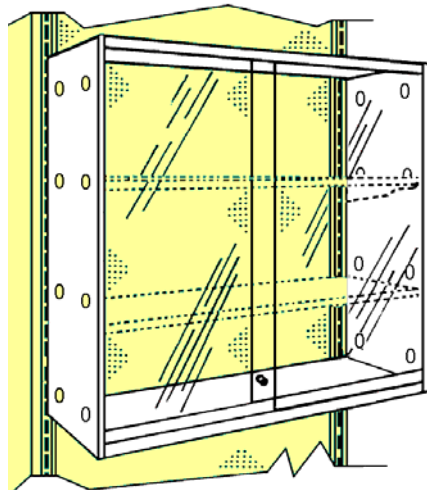

*With metal top, sides are perforated for storage of pesticides*

*16" deep x 47" high x 48" wide*

**VERTICAL FLOORING SAMPLE DISPLAY**



410-30-3653J 36" wide x 54" high

410-30-3672 36" wide x 72" high

**SLANTED FLOORING DISPLAY**



496-28-3654 28" x 38" x 54" high, un-assembled

**ALUMINIUM SLATWALL PANEL SYSTEM**



**FOR WAREHOUSING SYSTEM**

*Available in the following dimensions;*

*49 3/8', 97 3/8 et/and 103 3/8" wide*

*42, 48, 54, 60, 66, 72, 78, 84, 90 et/and 96" high*

*Can be adapted to fit onto Boni type gondolas.*

*Price on request*

**ALUMINIUM SLATWALL PANEL SYSTEM**

**ACCESSORIES**

**SIGN HOLDER**



**DRILL HOLDER**



**SIGN HOLDER WITH STOPPER**

*For shelf*

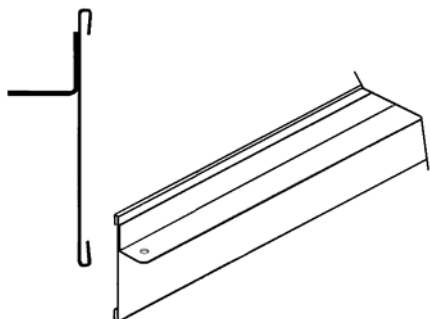

4951347J	47½"
4951397J	95½"
49513101J	101½"

**SIGN HOLDER WITHOUT STOPPER**

*For shelf*

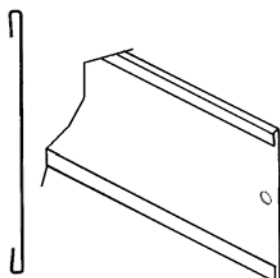

4951347JSA	47½"
4951397JSA	95½"
49513101JSA	101½"

**ALUMINIUM SLATWALL PANEL SYSTEM**

**ACCESSORIES**

**CIRCULAR SAW BLADE DISPLAY WITH 5½" PROJECTION**

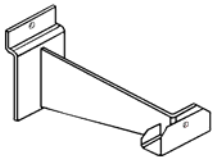

030-36-0512ASW *5½" slatwall bracket for circular saw blade display*

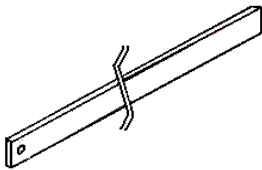

030-36-0148 *1" x 3/16" x 48" crossbar for circular saw blade display*

**CIRCULAR SAW BLADE DISPLAY WITH 8½" RODS**

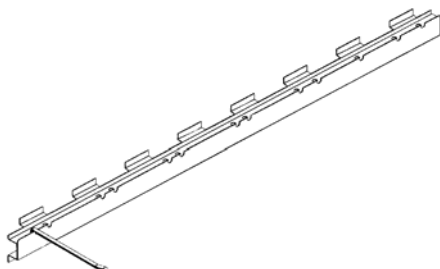

030-33-0248 *48" slatwall display*

030-33-0208G *8½" L-shaped rod*

**TOOL SECTION ACCESSORIES**

**DRILL DISPLAY**

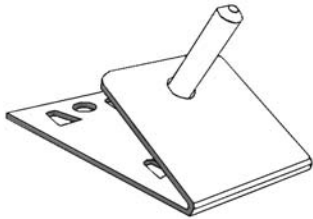

495-15-02J05 2 1/2" x 5" with 5/16" rod 45 degree angle

**DIVIDER**

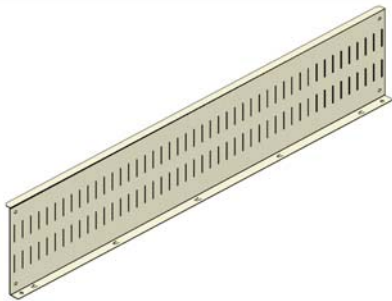

495-12-1045R *Back stopper for divider box with slots and hooks for perforated steel panel 10" high x 45 7/8" long*

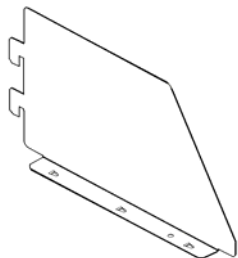

**Right side shown**

028-02-1316AD 16" x 1 1/4" x 10" - Right

028-02-1321AD 21" x 1 1/4" x 10" - Right

028-02-1316AG 16" x 1 1/4" x 10" - Left

028-02-1321AG 21" x 1 1/4" x 10" - Left

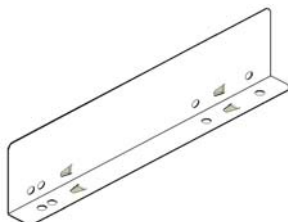

*Divider for perforated steel panel with hooks, 1" x 3" x 12'*

**TOOL SECTION ACCESSORY**



**SLEDGEHAMMER DISPLAY**

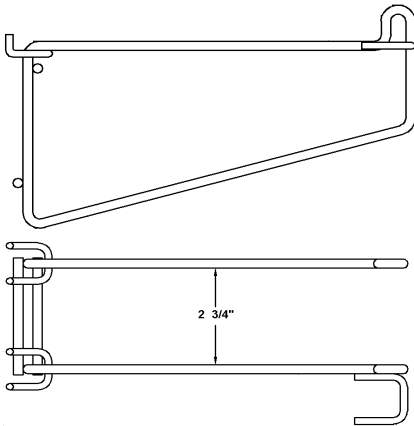

*For slatwall or pegboard panel  
10" long x 5 3/16" high rear / 3 1/2" front, with  
rod for flip-scan type label holder  
Spacing between each sides : 2 3/4"*

**AXE DISPLAY**

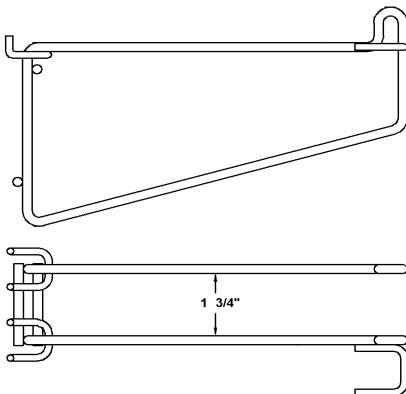

*For slatwall or pegboard panel  
10" long x 5 3/16" high rear / 3 1/2" front, with  
rod for flip-scan type label holder  
Spacing between each sides : 1 3/4"*